

G4 Digital Switch Modules

Features

- On/off switch, ideal for testing application software (input) or field wiring (output)
- Ability to simulate an external input or a G4 module output
- Input has a built-in LED status indicator and logic levels of 5, 15, and 24 VDC; it is debounced for rapid counting.
- Small footprint design matches other G4 I/O modules.
- Operating temperature: -30° C to 70° C
- UL recognized, CSA certified, CE approved
- Passes NEMA Showering Arc Test (ICS 2-230)
- Meets IEEE Surge Withstand Specification (IEEE-472)

Description

Because these G4 digital modules simulate input or output with a manual toggle switch, they are ideal for testing application software and field wiring. The G4SWIN input module's switch is on the logic side of the module, while the G4SWOUT output's switch is on the field side.

G4SWIN

Opto 22's G4SWIN input test module is used to simulate an input on an I/O mounting rack. Each module contains a toggle switch that closes a contact on the logic side of the module. An internal resistor limits the current through the switch and provides a load similar to that of an actual input module. An internal debounce circuit allows rapid switch closures without false counts.

The G4SWIN module works with logic voltages of 5, 15, and 24 volts. Internally, there is no connection to the field inputs.

The G4SWIN module is ideal for simulating discrete external events when testing application software.

G4SWOUT

Opto 22's G4SWOUT output test module provides a manual toggle switch on the field side. The switch closes a contact that shorts the field terminals to turn on a field output. Internally, there is no connection to the logic side of the module.

The G4SWOUT module is ideal for testing field wiring and devices by simulating an output from the computer. The switch can handle 3 amps at 250 VAC/VDC.



G4 Digital Switch Modules



Part Numbers

Part	Description
G4SWIN	G4 Digital Input Switch 5, 15, 24 VDC Logic
G4SWOUT	G4 Digital Output Switch, 250 VAC/VDC

G4 Digital Switch Modules

G4SWIN

Specifications

Isolation, input-to-output (transient): 1 ms 1 minute	4000 volts 1500 volts
Temperature: Operating Storage	-30 to +70 °C -30 to +85 °C

Dimensions

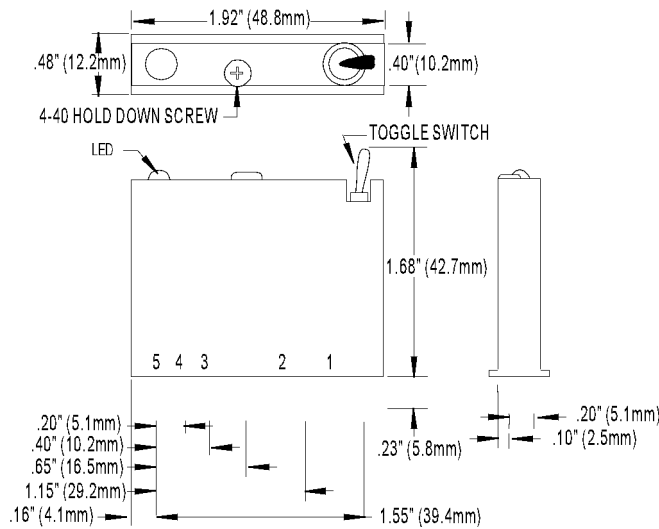

Schematics

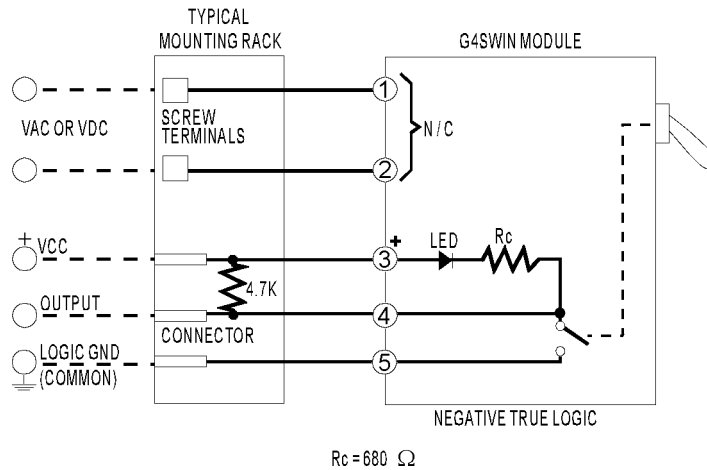

G4 Digital Switch Modules

G4SWOUT

Specifications

Output voltage range	250 VAC/VDC
Isolation, input-to-output (transient)	4000 volts
Temperature:	
Operating	-30 to +70 °C
Storage	-30 to +85 °C

Dimensions

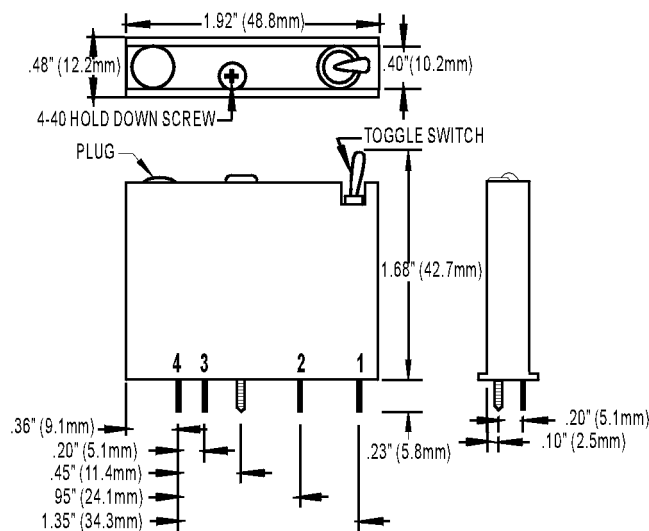

Schematics

